

TOOLMAKERS HAMMER

It is not that often that something totally unique appears, but this little toolmaker's hammer from Derek Winks of Kingsbury, London is just that. As can be seen from the photograph, this item has an almost ornamental appearance — it looks so good it should, perhaps, be on display in the home! Maybe two should be made, one for use and one to go on show

I had never come across this unusual tool until I recently saw a reference to it in an American book on workshop technology in the public library. It seemed to me that it would be a useful addition to the toolkit, especially for those like myself on the wrong side of 65 whose eyesight is not as keen as it was. It is simply a small hammer with a magnifying lens incorporated in the head. It is used for setting out the centres for drilled holes with a dot punch; the lens is used to locate the punch exactly on the scribed line before hitting it with the hammer, obviously quicker than using a separate lens. I have found the tool very useful for marking out those small components where precise location of holes is important but a conventional optical centre punch cannot be used as there is no flat surface to rest it on.

Lens

A suitable lens will have a diameter of about an inch with a focal length of around 2.5 to 3 inches. The one I used was one of a batch bought many years ago from a 'surplus' shop. It is an achromatic doublet mounted in a brass ring; it gives a clear image without colour fringing. I regret I cannot suggest a current source of supply as the only dealers in such goods that I knew have ceased trading. However, if all else fails, a lens from a watchmaker's eyeglass could be used; these are readily available from our usual advertisers and are not too expensive.

Construction

The head is built up from a mild steel centre piece, (Item 1 on the drawing) and two silver steel faces, Item 2. My first attempt was in solid silver steel, but it cracked badly on quenching. Both parts are simple turning jobs; the flat on the centre piece can be milled or filed. The face pieces are hardened in the usual way and tempered to dark straw, about 240deg. C (gas Mark 9 in the domestic oven) and fixed into the centre piece with high-strength Loctite. The tool illustrated in the American book had one flat face and a ball-pein, but I could not see much use for this, so I made it symmetrical with two flat faces.

The 'neck' portion of the hammer was built up from two parts silver-soldered together. Item 3 was cut from 1/4 in. thick mild steel flat with a bandsaw. If this is not available, a hacksaw and file will do but it's

rather hard work! The piece was then mounted in the four-jaw chuck and the hole for the lens mount bored. The diameter will of course depend on the lens used, so is not specified. The two holes for the 4BA Allen retaining screws were then drilled and counterbored. The part was then clamped to the head in the correct position and the holes spotted through, drilled and tapped 4BA. A tilting vice is a big help here. The part was completed by drilling the 1/4 in. hole to receive Item 4 and the 6BA hole for the grub screw.

Item 4 is a simple turning job from 1/4 in. mild steel rod. The two components were silver-soldered together with Easyflo, then cleaned up with files and carborundum paper.

Lens mount

This is a short length of thick-walled brass tube with some means of retaining the glass in position. The lens I used was already in a brass mount so that it was only necessary to bore the tube out to fit and to stick the lens in position with Loctite. If an unmounted glass is used, it will be necessary to fit a retaining ring, either screwed as in the drawing (Item 5) or if you do not want to bother with screwcutting, a Circlip-type ring fitting into a groove would do. The mount must be long enough to protect the glass from scratching when the tool is put down on the bench. The mount is retained in Item 3 by the 6BA Allen grub screw.

Handle

This was turned from a hickory club-hammer handle from the local DIY supermarket (Item 6). However, any reasonably tough hardwood would do. Drill the 1/4 in. hole down the middle, open out to 1/2 in. depth and tap the thread 1/4 in. Whit. This is coarse enough to hold in hardwood. Support the drilled end on a running centre in the tailstock and turn to shape. If proper wood turning tools and toolrest are not available, this simple shape can be 'scraped' with a sharp round-nosed tool and finished with files and glasspaper. The open end is made a light drive fit in the brass ferrule (Item 7). After turning, the handle was filed and sandpapered to an oval cross-section as shown, before staining and finishing with three coats of Danish oil.

This completes the tool; it only remains to screw the handle on and secure it with epoxy adhesive if it is a loose fit.

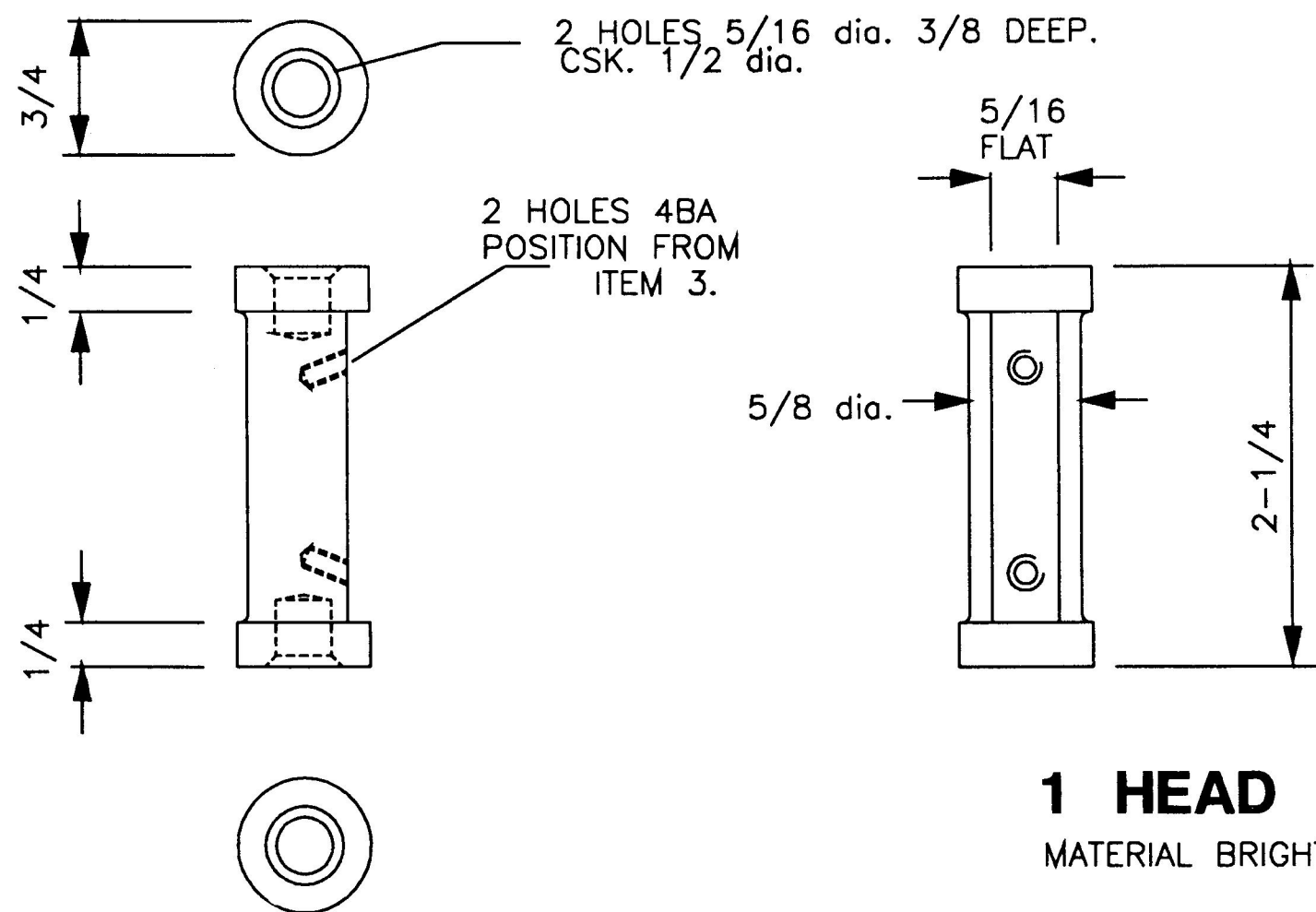
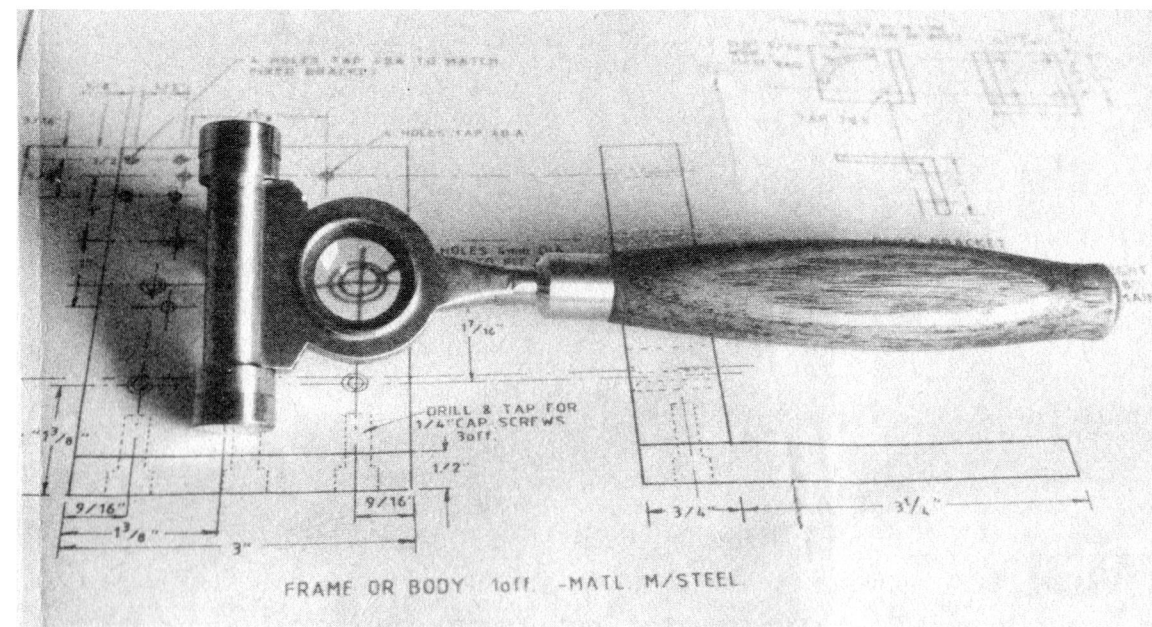

GENERAL ASSEMBLY

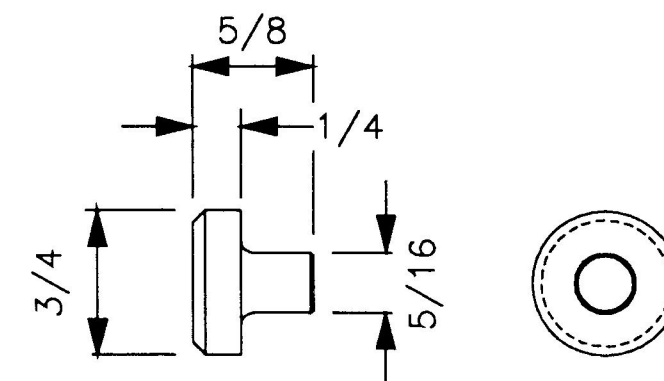
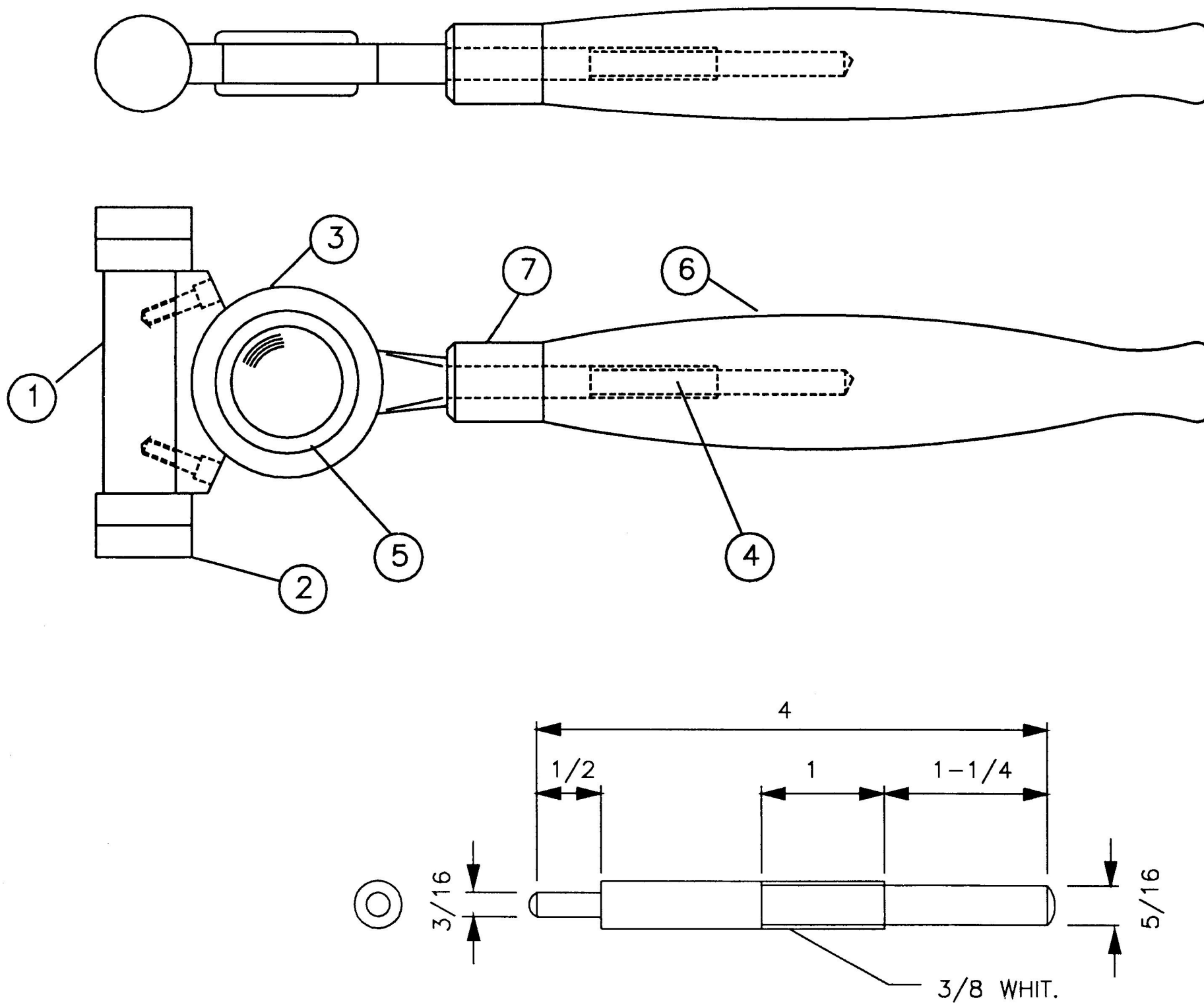

2 FACES

MATERIAL. SILVER STEEL.
2 OFF REQUIRED.