

FIG 4 AFTER
MACHINING IS COMPLETED.

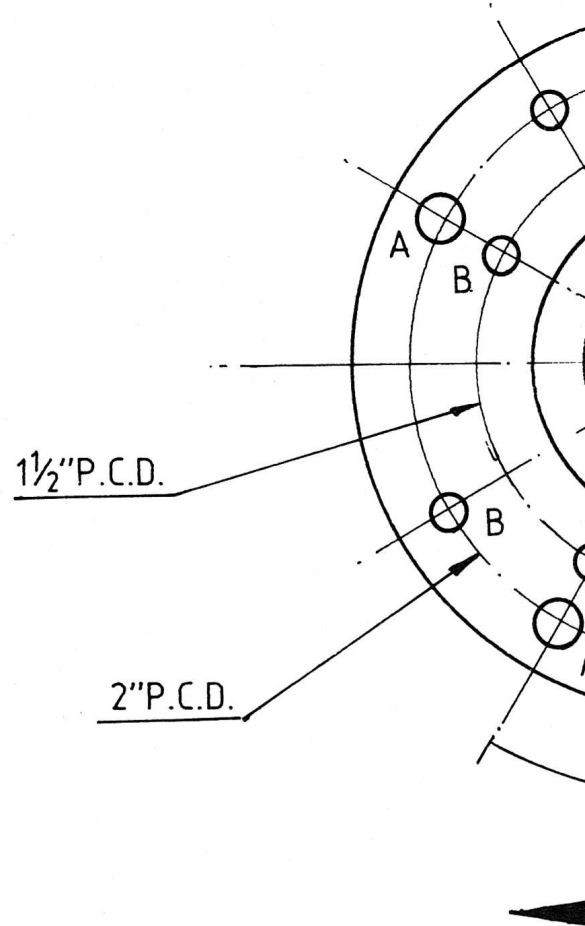
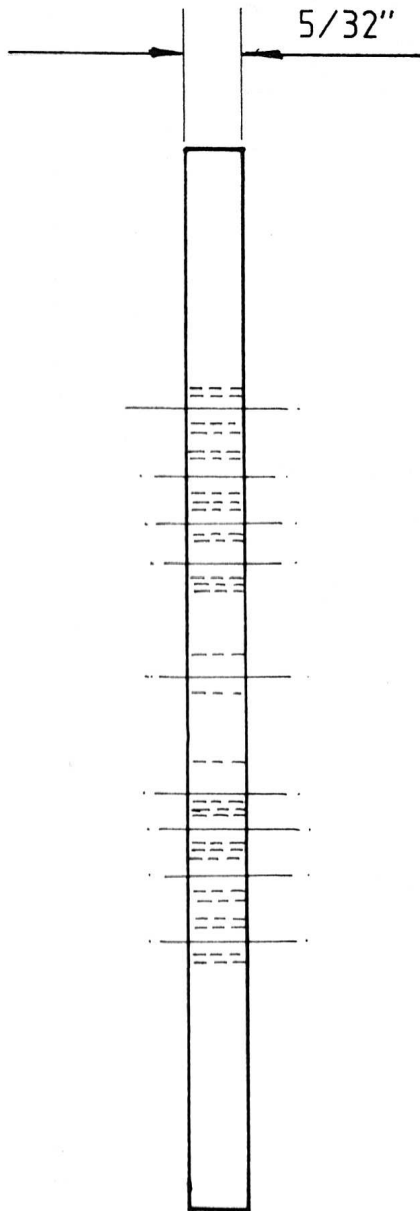
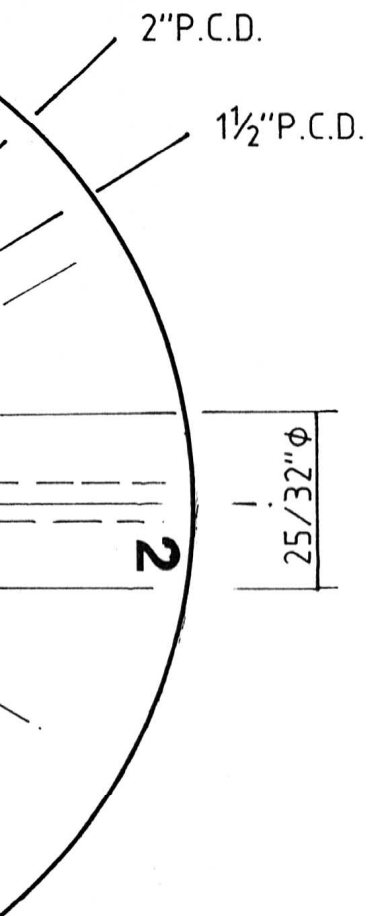

Fig 4.

② BACK PLATE.
CAST IRON OR MILD STEEL.

DETAILS DATA:-

A TAP M4

B TAP 2B.A.

& D REAM 1/8"φ