

ITEM 1 BASE PLATE MILD STEEL QTY 1

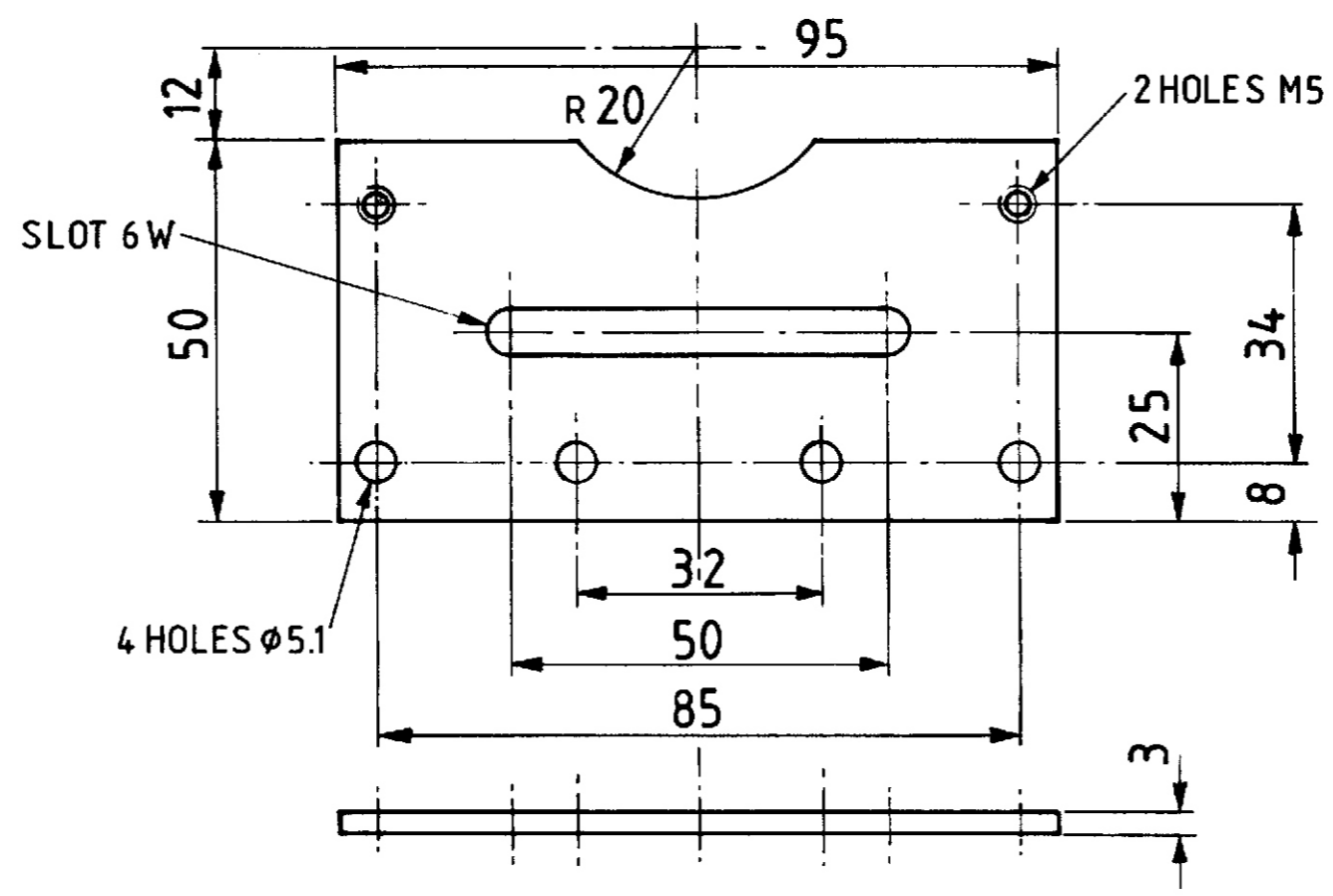

ITEM 3 FIXED PLATE MILD STEEL QTY 1

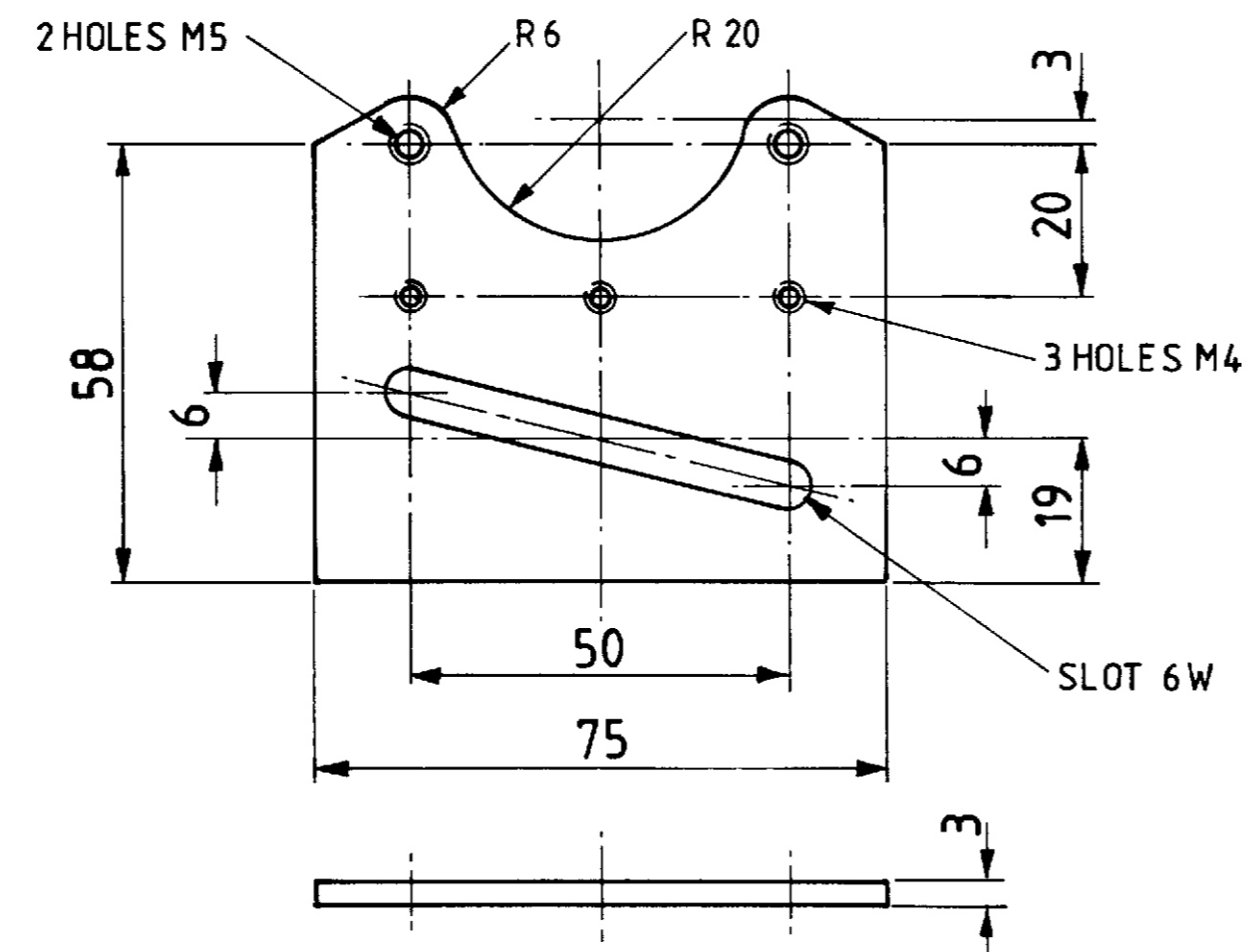

ITEM 4 SLIDE PLATE MILD STEEL QTY 1

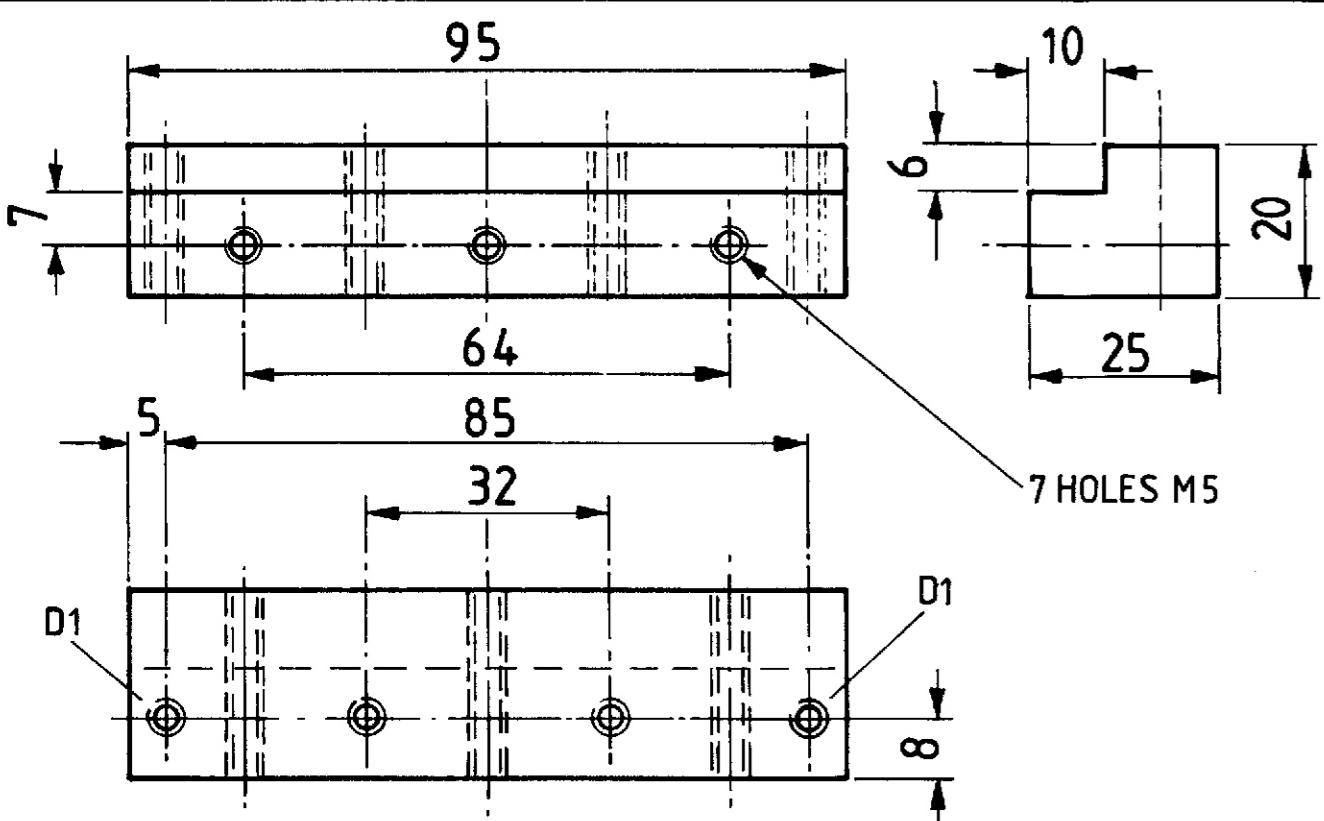

ITEM 2 BUTTRESS MILD STEEL QTY 1

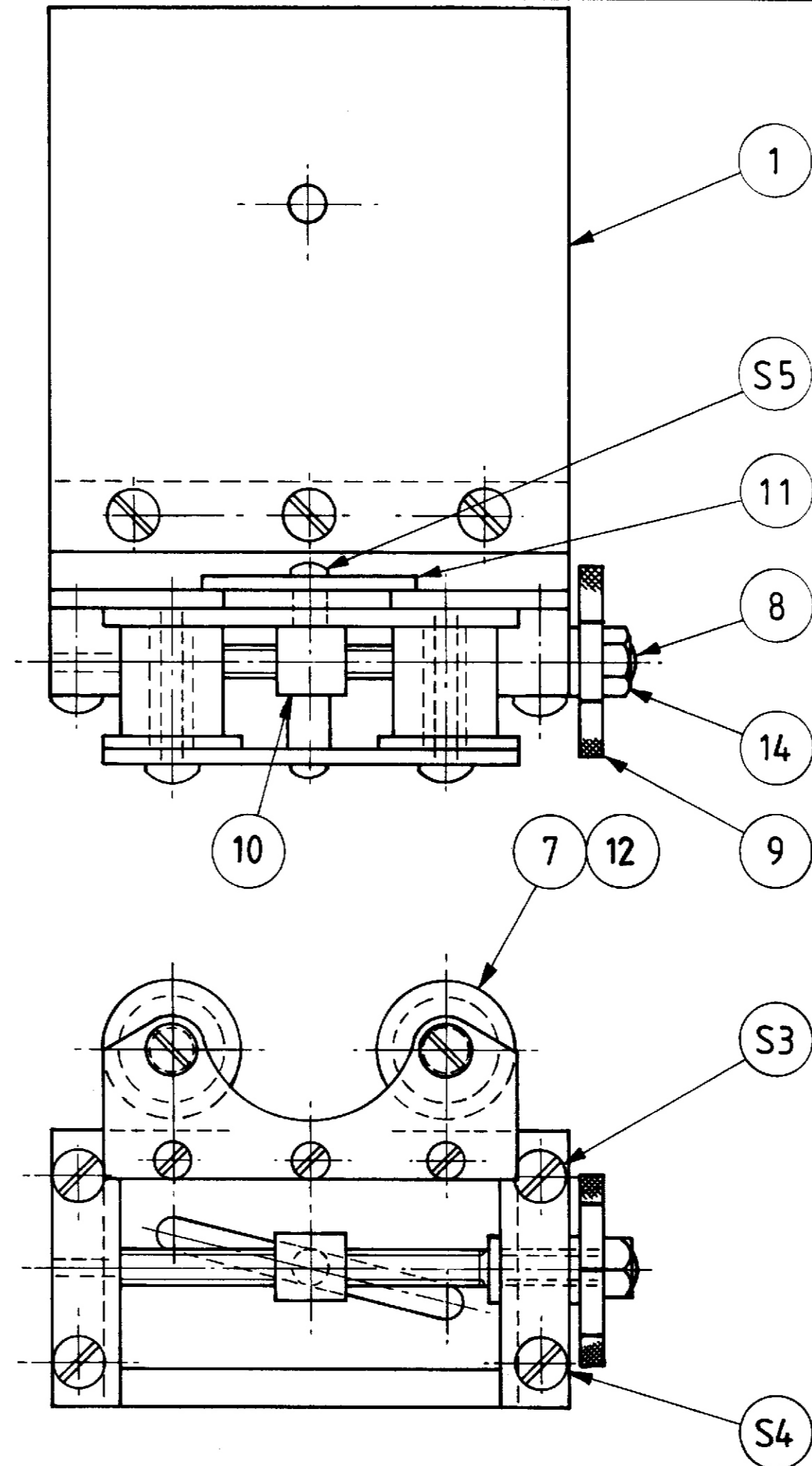

SCREW	SIZE	LENGTH	REMARKS	QTY
S1	M5	30	REDUCE LENGTH TO 28 ON ASSY	2
S2	M4	30	REDUCE LENGTH TO 28 ON ASSY	3
S3	M5	20		2
S4	M5	30		2
S5	M4	10		1
S6	M5	12		3

