

ITEM 5 SUPPORT PLATE MILD STEEL QTY 1

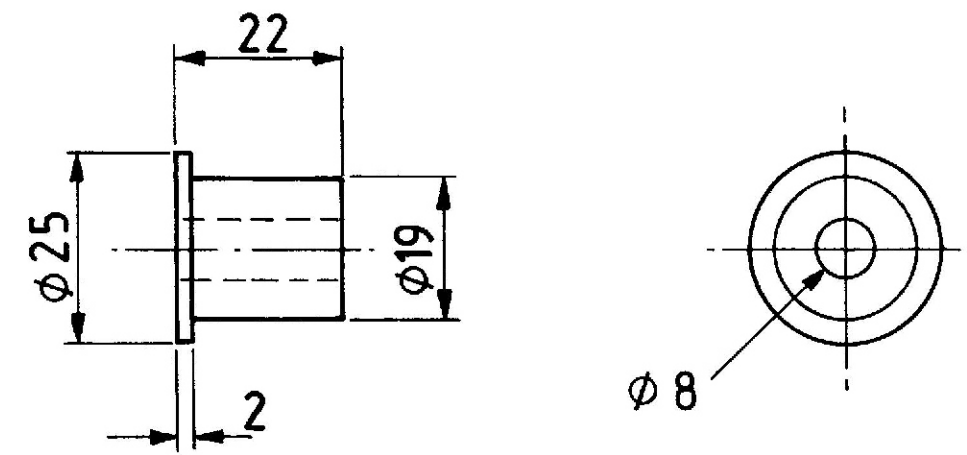

ITEM 7 ROLLER MILD STEEL QTY 2

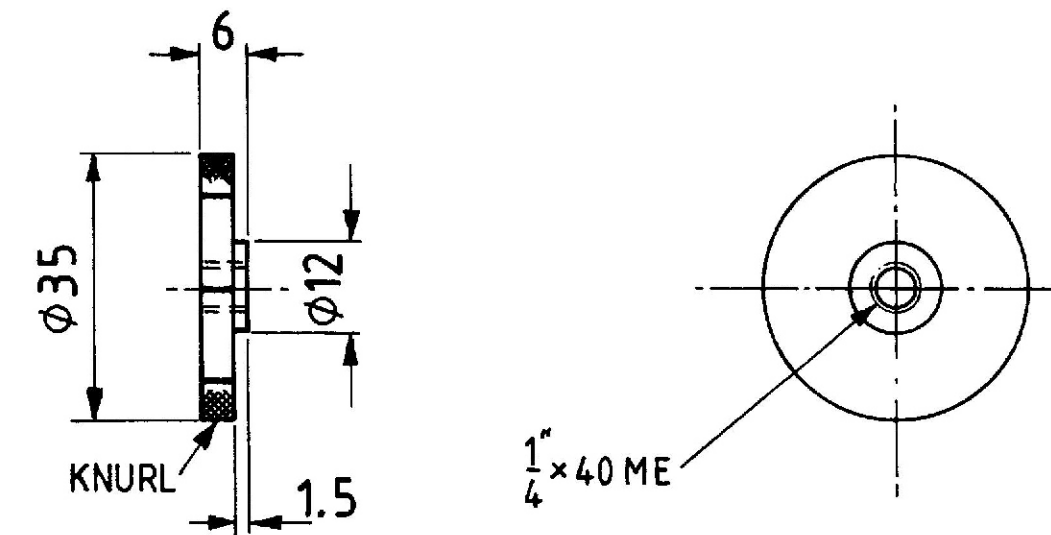

ITEM 9 ADJUSTING WHEEL MILD STEEL QTY 1

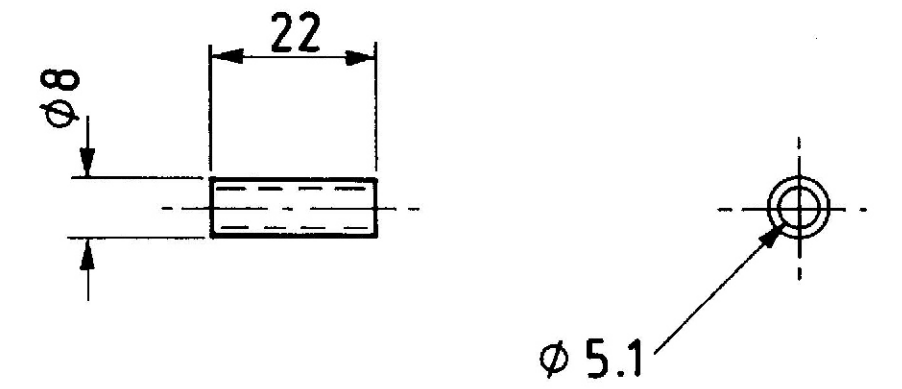

ITEM 12 ROLLER BUSH SILVER STEEL QTY 2

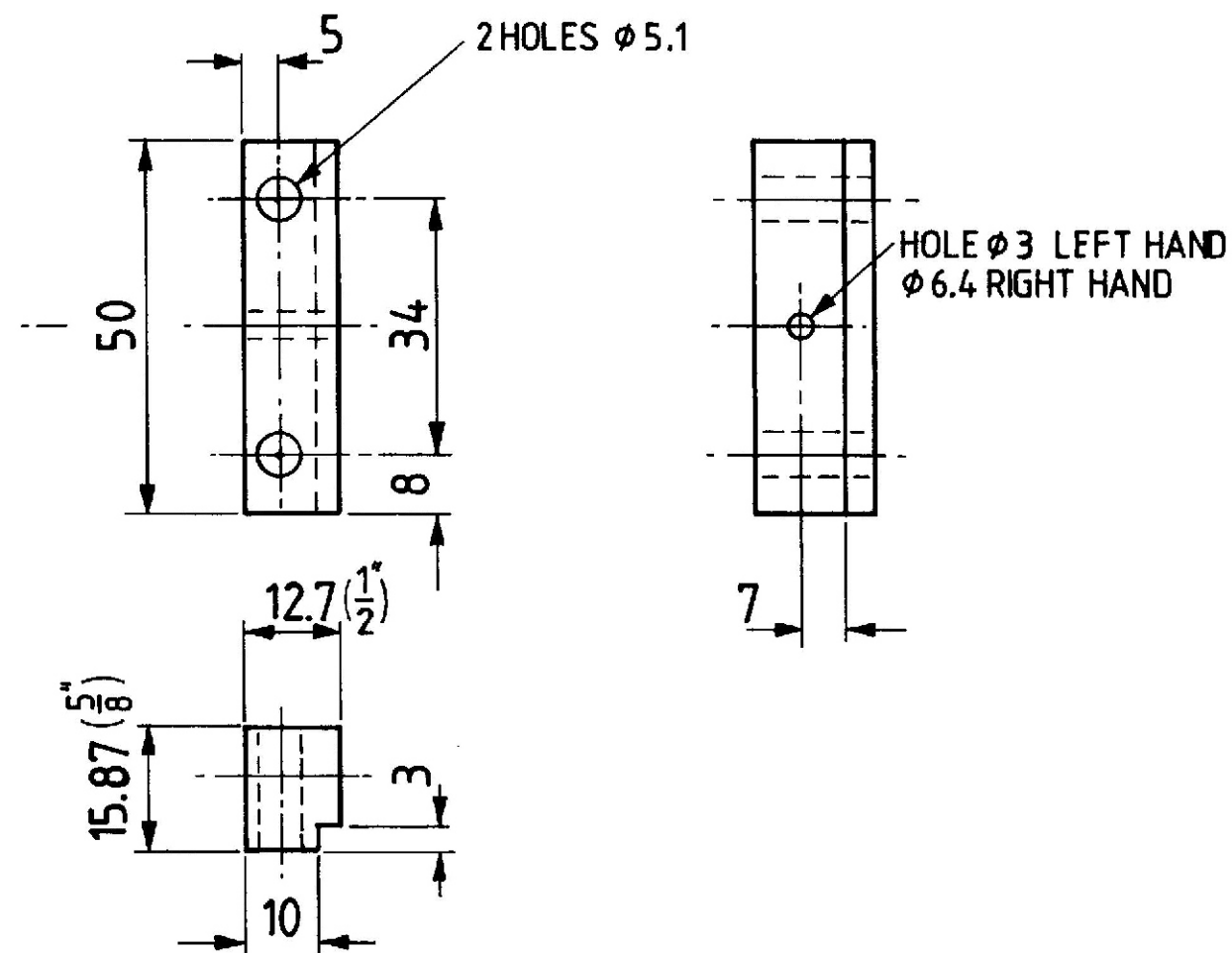

ITEM 6 GUIDE BLOCK MILD STEEL QTY 1 L.H. & 1 R.H.

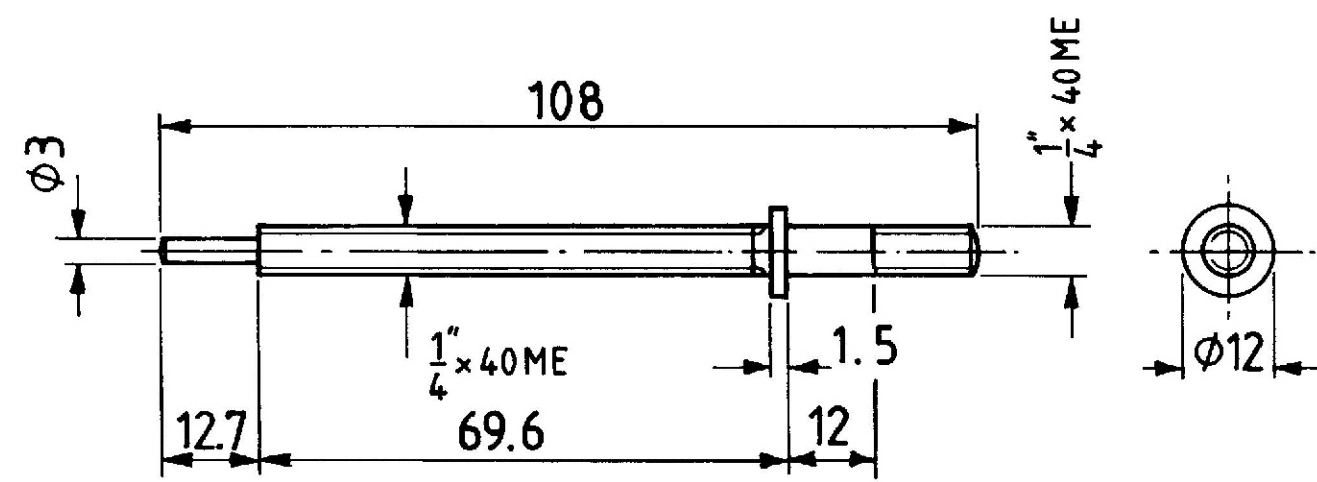

ITEM 8 ADJUSTING SHAFT MILD STEEL QTY 1

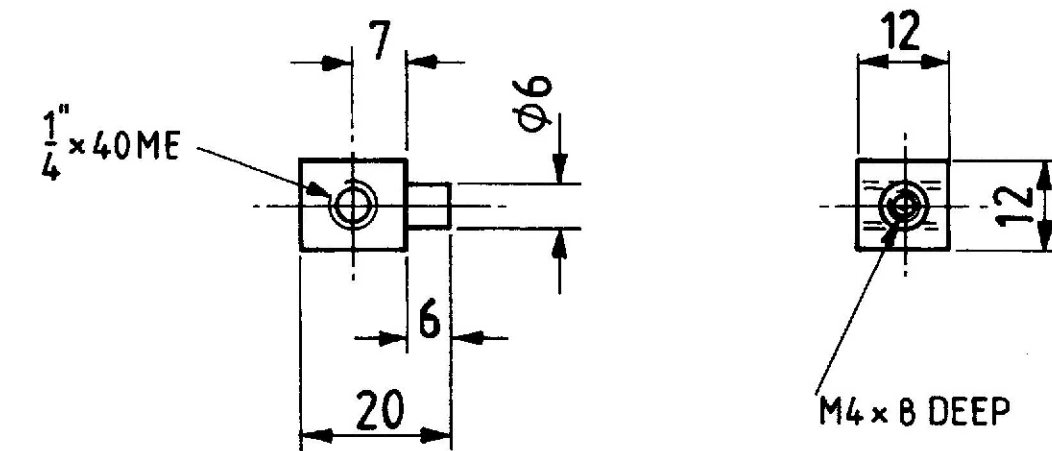

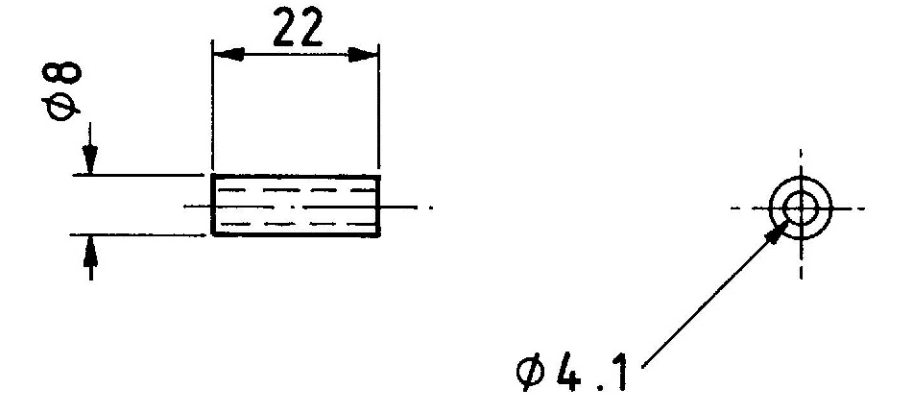

ITEM 10 DIE BLOCK MILD STEEL QTY 1



ITEM 13 SUPPORT SPACER MILD STEEL QTY 3

## A FILING REST

DESIGNED BY BOB FLETCHER.

 THIRD ANGLE PROJECTION DIMENSIONS IN MILLIMETRES  
 PRESENTED IN ISSUE 19 OF MODEL ENGINEERS WORKSHOP  
 COPYRIGHT ARGUS SPECIALIST PUBLICATIONS, ARGUS HOUSE,  
 BOUNDARY WAY, HEMEL HEMPSTEAD, HERTS. HP2 7ST

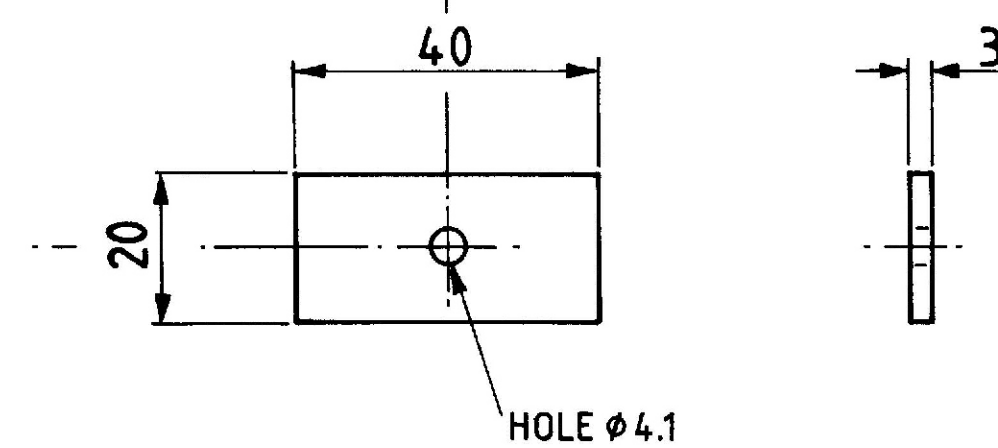

ITEM 11 DIE BLOCK KEEP PLATE MILD STEEL QTY 1

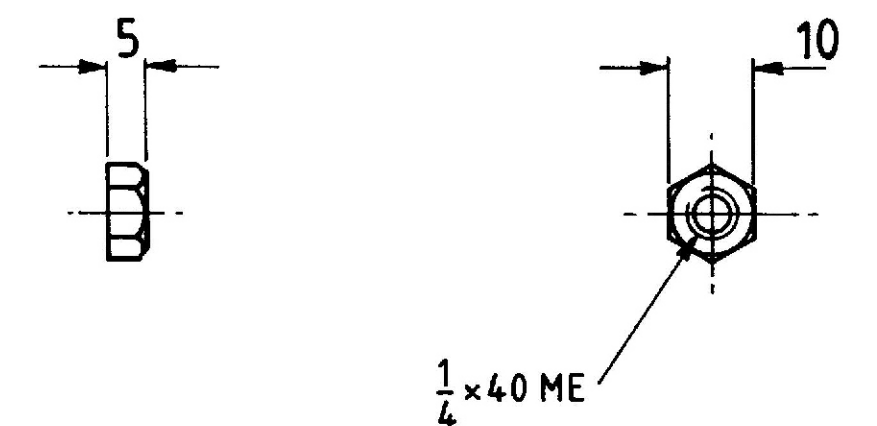

ITEM 14 NUT MILD STEEL QTY 1